



DAMAGE AND RESIDUAL SEISMIC PERFORMANCE EVALUATION OF REINFORCED CONCRETE SHEAR WALLS

M. Maeda⁽¹⁾, T. Koike⁽²⁾, N. Hosoya⁽³⁾, Y. Suzuki⁽⁴⁾, K. Tsurugai⁽⁵⁾, A. Nimura⁽⁶⁾

⁽¹⁾ Professor, Graduate School of Eng., Tohoku University, maeda@rcl.archi.tohoku.ac.jp

⁽²⁾ Graduate Student, Graduate School of Eng., Tohoku University, koike@rcl.archi.tohoku.ac.jp

⁽³⁾ Graduate Student, Graduate School of Eng., Tohoku University, hosoya@rcl.archi.tohoku.ac.jp

⁽⁴⁾ Assistant Professor, Graduate School of Eng., Osaka City University, ysuzuki@archi.eng.osaka-cu.ac.jp

⁽⁵⁾ Civil & Architectural Engineering Dept., Tohoku-Electric Power Co., Inc., tsurugai.kazuya.hd@tohoku-epco.co.jp

⁽⁶⁾ Chief Research Engineer, Kajima Technical Research Institute, Kajima Corporation., nimu@kajima.com

Abstract

A shear wall is an effective earthquake resistant element in a reinforced concrete structure with its high stiffness and shear strength. Therefore, shear walls are widely used for reinforced concrete building structures in Japan. Once an earthquake occurs, initial damage such as cracks tends to appear in shear walls because of higher stiffness. In general, cracks are observed from the early stage of lateral loading in a experiment of reinforced concrete structures thus cracks in concrete do not directly correspond to deterioration of seismic performance if sufficient reinforcement are provided. However, ordinary people such as building owners and users generally considered cracks as damage and decrease of structural performance. Therefore, it is important to correlate damage level with deterioration rate of performance in reinforced concrete structures and develop a methodology to evaluate residual seismic capacity in order to explain clearly damage level to ordinary people.

Guideline for post-EQ Damage Evaluation is published in Japan and a damage evaluation method is proposed[1]. In the Guideline, damage levels of structural elements are classified into five classes (I,II,III,IV,V). Seismic capacity reduction factor for each damage class are given by which residual seismic performance can be calculated. However, most of previous experimental data used in the Guideline are derived from loading test of structural elements of frame structure without shear walls such as beams and columns.

From these back ground, static loading tests of shear walls are conducted in this paper. Five shear wall specimens are tested. The test parameter is damage level (damage class) of shear walls. Namely, different levels of damage was induced to four specimens(I,II,III,IV) by “pre-loading”. Meanwhile, one specimen is tested without pre-loading. Degradation in lateral strengths, ductility, stiffness and energy dissipation capacity of damaged shear walls are focused on as main parameter for residual seismic performance, and studied through comparison with undamaged specimen. Damage situation such as crack width and bar yielding is observed during the test and relation with their residual seismic performance is investigated.

From experiment result, it was found that damage level in shear wall does not strongly influence the performance at the ultimate state, such as maximum shear force, deformation and energy dissipation capacities. On the other hand, in the state of the deformation experienced in preloading, the stiffness degraded.

FEM analysis evaluated well the performance such as shear strength and ultimate deformation for not only undamaged but also damaged specimens except equivalent stiffness during pre-loading range in heavily damaged specimens that has experienced large deformation such as 6/1000rad.

Keywords: residual seismic performance, reinforced concrete, shear wall, damage, crack width, shear strength, deformation capacity, energy dissipation capacity



1. Introduction

A shear wall is an effective earthquake resistant element in a reinforced concrete structure with its high stiffness and shear strength. Therefore, shear walls are widely used for reinforced concrete building structures in Japan. Once an earthquake occurs, initial damage such as cracks tends to appear in shear walls because of higher stiffness. In general, cracks are observed from the early stage of lateral loading in an experiment of reinforced concrete structures thus cracks in concrete do not directly correspond to deterioration of seismic performance if sufficient reinforcement are provided. However, ordinary people such as building owners and users generally considered cracks as damage and decrease of structural performance. It is important to correlate damage with deterioration of performance in reinforced concrete structures and develop a methodology to evaluate residual seismic capacity in order to explain clearly damage level to ordinary people.

In Japan, Post-earthquake Damage Evaluation Guideline, originally issued in 1990, was revised in 2001 and 2015 [1]. In the Guideline, damage class of structural elements are classified into five classes according to Table 1, based on damage situation such as residual crack widths, spalling and crush of concrete, and buckling and/or fracture of steel bars. Authors proposed a quantitative evaluation method of residual seismic performance for RC frame structure in previous researches [2,3,4] and the damage evaluation method was employed in the revised Guideline and damage level of a whole building is rated by residual capacity ratio. However, as for shear walls, damage evaluation for structures with shear walls is not examined enough because of lack of experimental data focused on damage and performance deterioration in shear walls. After the 2011 East Japan Earthquake, small cracks occurrence and elongation of vibration period was reported in some of nuclear power facilities, which are reinforced concrete shear wall structure [5]. A study on correlation of damage with residual capacity in shear wall is of great importance in order to confirm the safety of shear wall structures against aftershocks.

In this paper, static cyclic loading tests of reinforced concrete shear wall specimens was conducted and the influence of different levels of damage on structural performance degradation such as strength, deformation capacity and energy dissipation capacities when shear wall was damaged by vibration due to earthquakes.

Table 1 – Damage classes of structural elements in Japanese damage evaluation guideline [1]

Damage class	Damage situation
I	Some cracks are found. Crack width is smaller than 0.2 mm.
II	Cracks of 0.2 - 1 mm wide are found.
III	Heavy cracks of 1 - 2 mm wide are found. Some spalling of concrete is observed.
IV	Many heavy cracks are found. Crack width is larger than 2 mm. Reinforcing bars are exposed due to spalling of the covering concrete.
V	Buckling of reinforcement, crushing of concrete and vertical deformation of columns and/or shear walls are found. Side-sway, subsidence of upper floors, and/or fracture of reinforcing bars are observed in some cases.

2. Experimental Plan

2.1 Outline of experiment

Five reinforced concrete shear wall specimens with common dimensions and reinforcing arrangements were prepared. The shear wall was designed to be shear critical walls as about 1/4 scale of prototype reactor building of a nuclear power plant. The test parameter is damage level of shear walls and different levels of damage is induced to four specimens (S-DI, II, III, IV) by “pre-loading” as shown in Table 2. Specimen (S-D0) is tested without pre-loading to investigate capacity of the original shear wall and deterioration by damage due to pre-loading through comparison with results of damage walls. Note that specimen S-DII was re-used as specimen S-DIV after loading test as specimen S-DII because damage was quite limited and deterioration of capacity by pre-loading was regarded as negligible.



Table 2 – Summary of specimens

	Name of specimen	S-D0	S-DI	S-DII	S-DIII	S-DIV
Parameter	Damage class	0 (None)	I (Slight)	II (Minor)	III (Moderate)	IV (Severe)
Shear wall	Height (mm)	1000				
	Length (mm)	1800				
	Thickness (mm)	120				
	Arrangement of reinforcement	D6@40(SD295) Double				
	Reinforcement ratio (%)	1.32				
	Axial stress (MPa)	0.50				
	Shear span to depth ratio (MPa)	0.29				
Column	Section b × D (mm)	200 × 200				
	Main reinforcement	12-D16(SD345)				
	Hoop reinforcement	2-D10(SD345) @60				
Beam	Section b × D (mm)	400 × 400				
	Main reinforcement	10-D22(SD390)				
	Hoop reinforcement	2-D13(SD390)@100				
Shear cracking strength by AIJ[6] (kN)		357				
Ultimate shear strength by AIJ[6] (kN)		1499				
Ultimate shear strength by AIJ [7] (kN)		1078				
Crack flexural strength by AIJ[7] (kN)		647				
Ultimate flexural strength by AIJ[7] (kN)		3769				

Shear cracking, ultimate shear and flexural strengths were calculated by current design guidelines[6,7]. Two design equation were employed for prediction of the ultimate shear strength; one is AIJ's (Architectural Institute of Japan) design guideline based on the truss and arch theory (Eq. (1)) [6], and another is JEAG's guideline [8]. To determine the deformation at the time of each damage class from the experimental results by loading of specimen S-D0, it decided the size of the deformation given in the pre-Loading for S-D I ~IV.

$$V_u = t_w l_{wb} p_s \sigma_{sy} \cot \phi + \tan \theta (1 - \beta) t_w l_{wa} v \sigma_B / 2 \quad (1)$$

$$\beta = \{ (1 + \cot^2 \phi) p_s \sigma_{sy} \} / v \sigma_B, \quad \tan \theta = \sqrt{(h_w / l_{wa})^2 + 1} - h_w / l_{wa}$$

Where, t_w : Thickness(mm), l_{wa} , l_{wb} : Equivalent wall length(mm), p_s : Shear reinforcement ratio of the wall, v : Effective compression strength coefficient, σ_{sy} : Strength of the shear reinforcement of the wall
 σ_B : Compressive strength of concrete, ϕ : Angle of concrete compression bunch of truss mechanism
 h_w : Wall height(mm)

2.2 Outline of specimens

Reinforcing bar arrangement is shown in Fig.1. Specimens have two columns in both sides of a wall panel, top and base beams. The entire height of a specimen is 1800mm, and wall panel height is 1000mm. Wall panel thickness is 120mm with web reinforcement of double layer of D6@40(SD295).

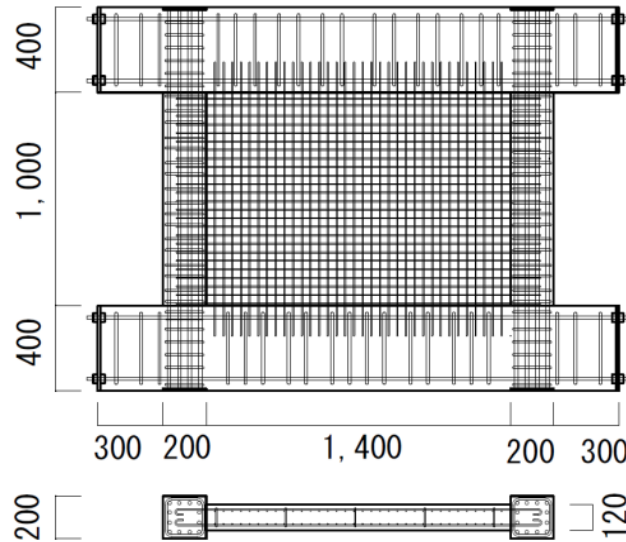

Fig. 1 – Reinforcing detail of specimen: elevation and section

2.3 Loading plan

Loading setup is shown in Fig.2. Vertical loads are applied to the full cross-section of the wall and columns by two vertical hydraulic jacks so that constant axial stress is about 0.5MPa. Cyclic horizontal loads are applied by two hydraulic jacks fixed at the mid-height of the wall panel as an inflection point agrees with the mid-height. As a result, shear span ratio to depth of a wall specimen is about 1/4. Loading, except to specimen S-D0 carry out a pre-loading in order to reproduce the situation of damage for shear wall after receiving the earthquake. After that, we start main-loading. (Fig.3) By doing this loading, we compare and examine whether the damage level after the earthquake affects the subsequent structure performance degradation.

Cyclic loading history is shown in Fig.3. Loading schedule for specimen S-D0 consists of two cycles at each story drift angle from 0.25/1000 rad. to failure without pre-loading as shown in Table 3. Damage level of shear wall was recorded at each drift angle as a reference for selection of maximum drift of pre-loading for damaged specimens. Loading schedule for specimen S-DI to S-DIV is shown in Table 4. Maximum drift angle in pre-loading was selected so that target level of damage was induced to wall panel. After five cycles of loading at the target damage level, specimen was unloaded by gradually reduced cyclic loading.

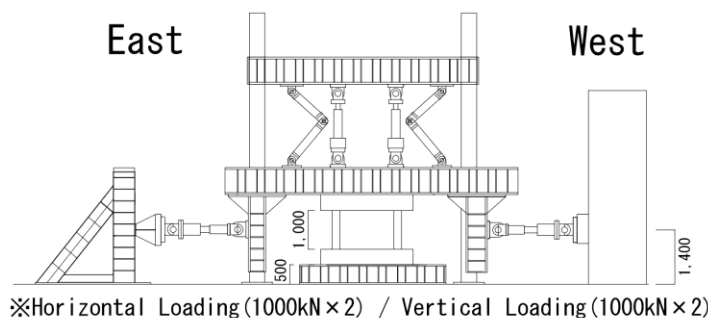

Fig.2 – Loading test setup

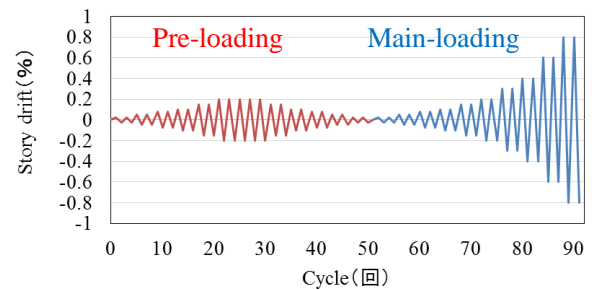

Fig.3-Loading history

Table 3–Loading schedule: S-D0

	Pre-Loading													
	Story Drift R/(1000rad.) and Number of Each Cycle (Time)													
Specimens	±0.25	±0.5	±0.75	±1	±2	±3	±4	±6	±4	±3	±2	±1	±0.5	±0.25
S-D0	None													
	Main Loading													
	Story Drift R/(1000rad.) and Number of Each Cycle (Time)													
Specimens	±0.25	±0.5	±0.75	±1	±1.5	±2	±2.5	±3	±4	±6	±7	8		
S-D0	2	2	2	2	2	2	2	2	2	2	2	2	2	2

3. Experimental results of the experiment: S-D0

3.1 Shear force-displacement relationship and failure behavior of specimen S-D0 without damage

Shear force-story drift angle relationship of specimen S-D0 is shown for Fig.4 associated with a back bone curve calculated by JEAC design guideline [4]. Initial cracks were observed at the wall panel corner and cracks generated in entire wall panel at the loading cycle of 2/1000rad (see Fig.5). reinforcing bar yielded and fine spalling of concrete in wall panel was observed at the center of wall panel at cycle of 6/1000rad. At cycle of 8/1000rad, shear force reached to the maximum and, at the same time, crush of concrete and rapid drop in shear force occurred. Process of growth of cracks and crush in concrete is shown in Fig.6. Note that damage such as cracks and crush was recorded only left side part of a specimen (Fig.5), because symmetrical damage pattern can be predicted because of symmetrical stress distribution in a specimen.

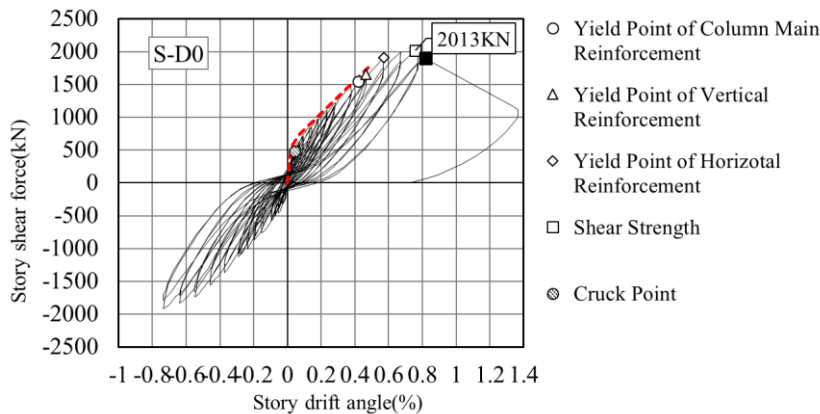

Fig. 4– Shear force-story drift angle relationship of S-D0



Fig.5–Damage at ultimate stage

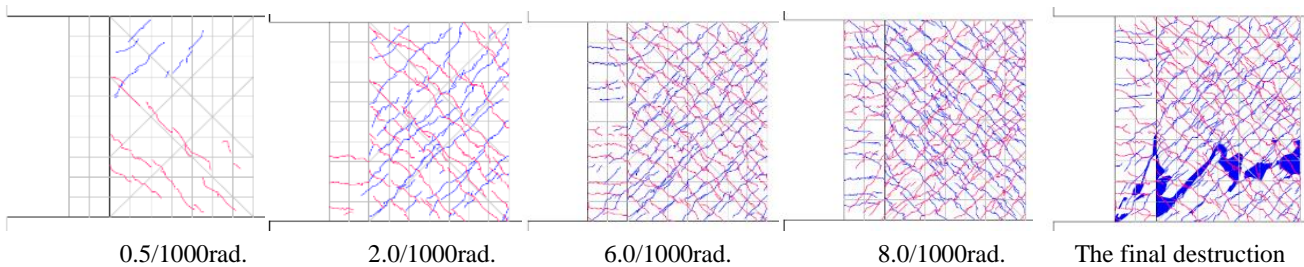

Fig. 6–Cracking maps of specimen S-D0

3.2 Classification of damage class in specimen S-D0

In Japan, damage level of reinforced concrete structural members is classified according to Japanese “Guideline for post-EQ Damage Evaluation” [1]. In the guideline, damage class is classified based on basic concept of shear force- deformation curve and Table 1. experimental data such as cracks, shear force-deformation relationship and stiffness degradation were examined and compared with judging criteria for damage classes, and judged the damage class. Cracks are related to strain of the reinforcement, the larger strain become, the more expand cracks as shown in Fig.8,

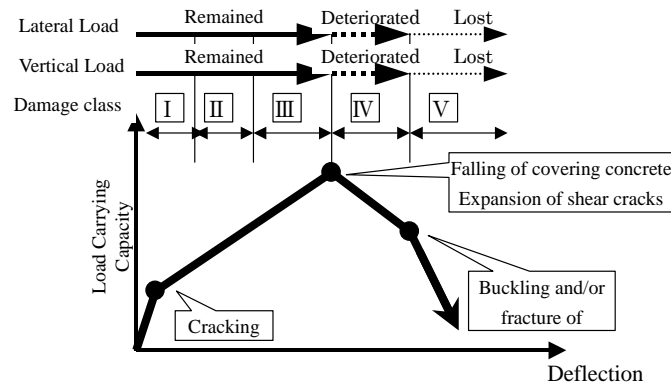

Fig. 7—Idealized lateral force-displacement relationships and damage class[2]

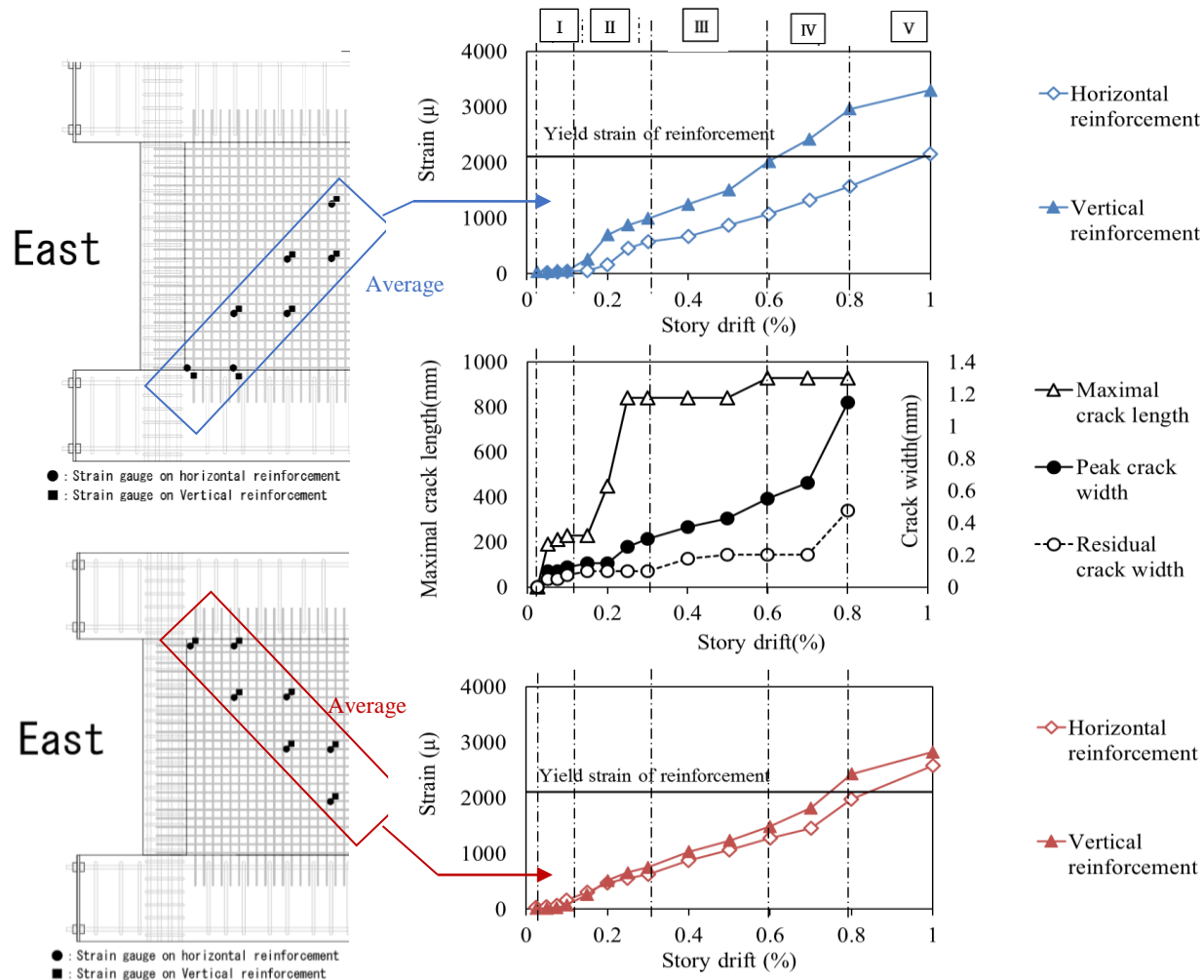

Fig. 8—Relationship between crack width/length and strain of reinforcement in wall panel

Based on the above understanding, damage class, stiffness degrading ratio and crack width/length are integrated in Fig.9. From this result, story drifts required by each the damage level were determined. Specifically, damage class I is a cracking drift $\sim 1/1000\text{rad}$, Damage class II is $1/1000\text{rad} \sim 3/1000\text{rad}$, Damage class III is $3/1000\text{rad} \sim 6/1000\text{rad}$, and Damage class IV is $6/1000\text{rad} \sim$ ultimate shear strength. Thus, pre-loading for specimen S-DI~IV was carried out as shown in Table 4.

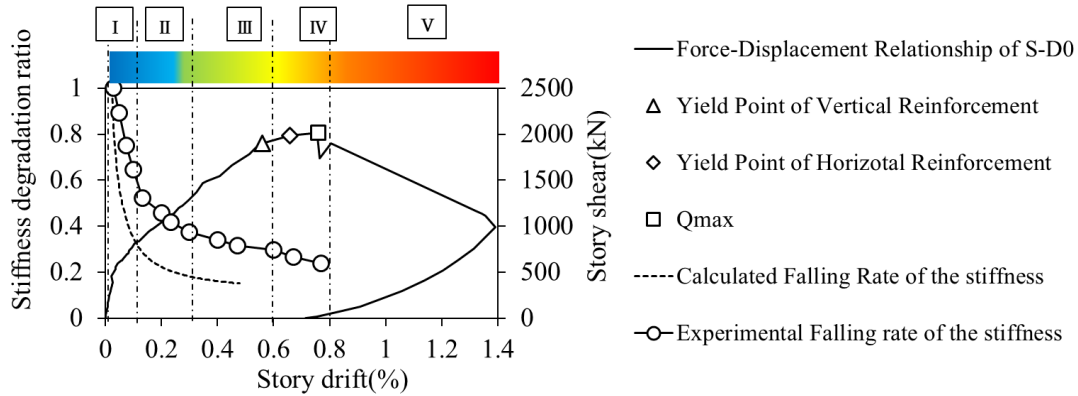

Fig. 9(a)–Damage class and stiffness degrading ratio

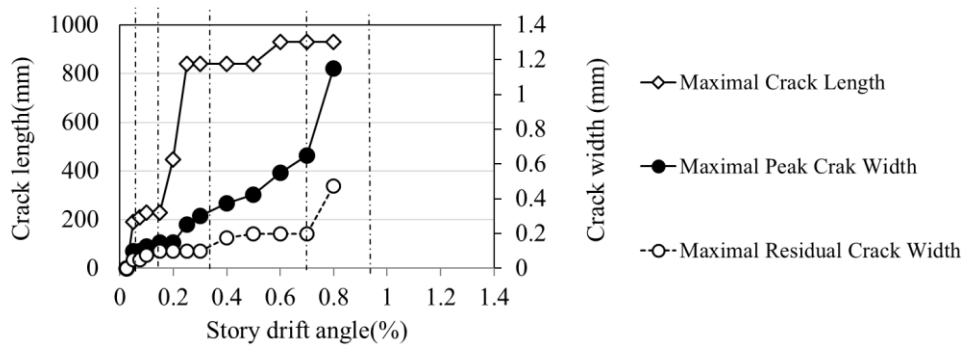

Fig. 9(b)–Damage class and crack width/length

Table 4 – Loading schedule of damaged specimens: S-D I ~S-DIV

	Pre-Loading													
	Story Drift R/(1000rad.) and Number of Each Cycle (Time)													
Specimens	± 0.2 5	± 0.5	± 0.75	± 1	± 2	± 3	± 4	± 6	± 4	± 3	± 2	± 1	± 0.5	± 0.25
S-D I	2	5	5										2	2
S-D II	2	2	2	2	5							2	2	2
S-D III	2	2	2	2	2	2	5			2	2	2	2	2
S-D IV	2	2	2	2	2	2	2	5	2	2	2	2	2	2
	Main Loading													
	Story Drift R/(1000rad.) and Number of Each Cycle (Time)													
Specimens	± 0.25	± 0.5	± 0.75	± 1	± 1.5	± 2	± 2.5	± 3	± 4	± 6	± 7	8		
S-D I														
S-D II														
S-D III	2	2	2	2	2	2	2	2	2	2	2	2	2	2
S-D IV														

4. Experimental results of damaged specimens: S-D I ~S-DIV

4.1 Shear force-story drift angle relationship of damaged specimens

Fig.10 shows shear force-story drift angle relationship of positive loading parts for damaged specimens S-DI-IV. All of the specimen indicate similar trend with un-damaged specimen S-D0, cracks generated from the wall corners, reinforcing bars yielded at the cycle of 6/1000rad. The specimens reached the maximum shear force at the drift angle of 8/1000rad. After that the peak, specimens suddenly lost shear resistance with shear failure of wall panels. Further, it can be seen from the damage at ultimate stage of each test body shown in Fig.11, the spalling area increased when the damage level of specimen was higher.

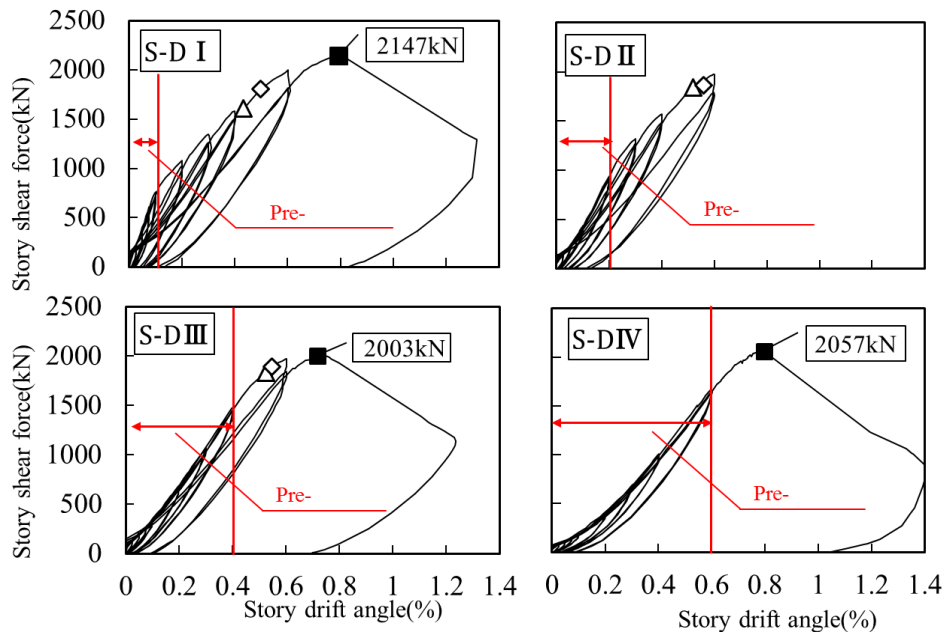

Fig.10–Shear force-story drift angle relationship of damaged specimens



(a)S-D I

(b)S-D III

(c)S-D IV

Fig.11– Damage at ultimate stage

4.2 Relationship between story drift and stiffness degrading ratio

Relationship between story drift and stiffness degradation ratio is shown in Fig.12, and stiffness degradation in each damage class is shown in Table 5. The initial stiffness is calculated by Least-square method from the initial loop of 0.25/1000rad cycle and the equivalent stiffness is calculated as a slope of a line connecting the positive and negative peak point in each cycle. Even in case of damage class I with small deformation and limited damage, stiffness decreased to about 60% of the initial stiffness due to cracking. Equivalent stiffness, within deformation experienced in pre-loading, decrease as damage class increase. On the other hand, beyond the experienced deformation, no difference was found in stiffness between damaged and undamaged specimens.

Table 5 – Damage class and stiffness degrading ratio

Damage level	Stiffness degrading ratio
I (Slight)	0.6
II (Minor)	0.36
III (Moderate)	0.27
IV (Severe)	0.22

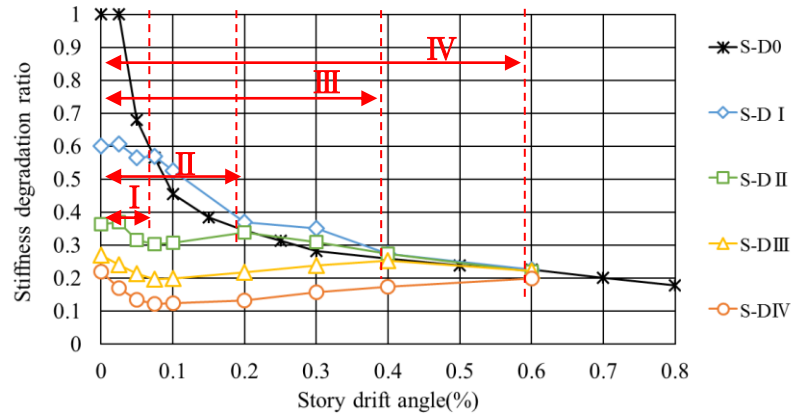

Fig.12–Stiffness degrading ratio

4.3 Comparison of shear strength and deformation capacity

Envelope of shear force-deformation relationships for all the specimens is shown in Fig.13. In a region within the maximum deformation in pre-loading, shear force of damaged specimens decreases due to the degradation of equivalent stiffness as shown in Fig. 12. However, recovery of shear resistance can be seen from the figures when deformation exceeds the maximum in the pre-loading and no significant effect of damage on ultimate shear strength and deformation capacity was found in the shear wall investigated in this paper.

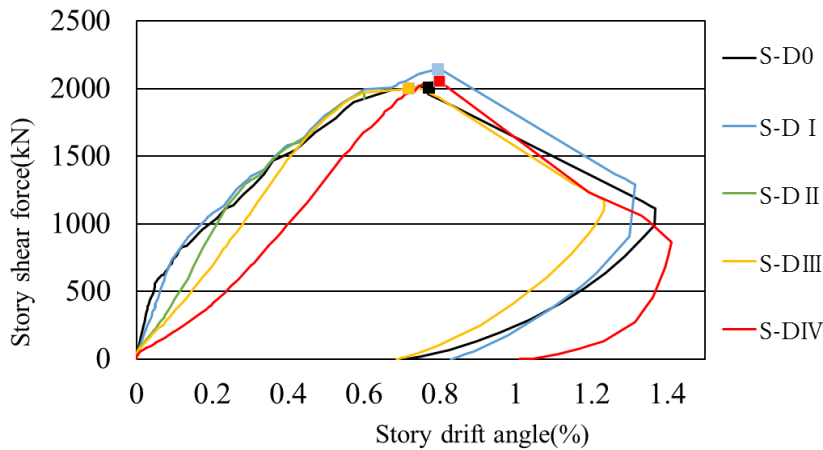

Fig.13(a) – Envelopes of shear-force – story drift curves with different levels of damage

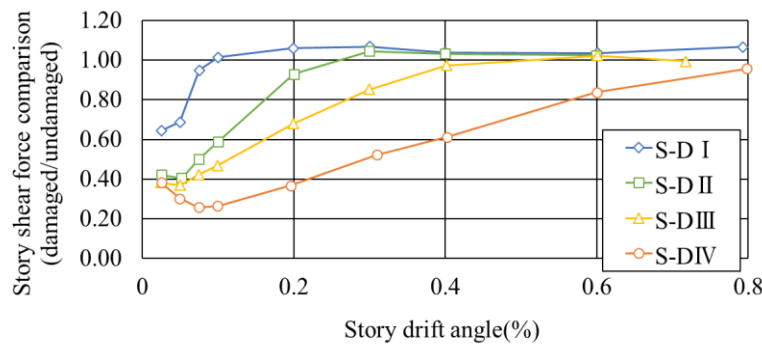

Fig.13(b)– Comparison of story shear force in each cycle

4.4 Comparison of equivalent viscous damping factor

As shown in Fig.14, equivalent viscous damping factor h_{eq} of heavily damaged specimens, S-DIII and S-DIV, are larger than the other specimens in small deformation. However, when the deformation becomes larger, there is no big difference among the specimens with different levels of damage, although heavily damaged specimen tend to have smaller damping factor. Significant effect of damage on damping factors was not observed as was found in shear strength and deformation capacity in 4.3.

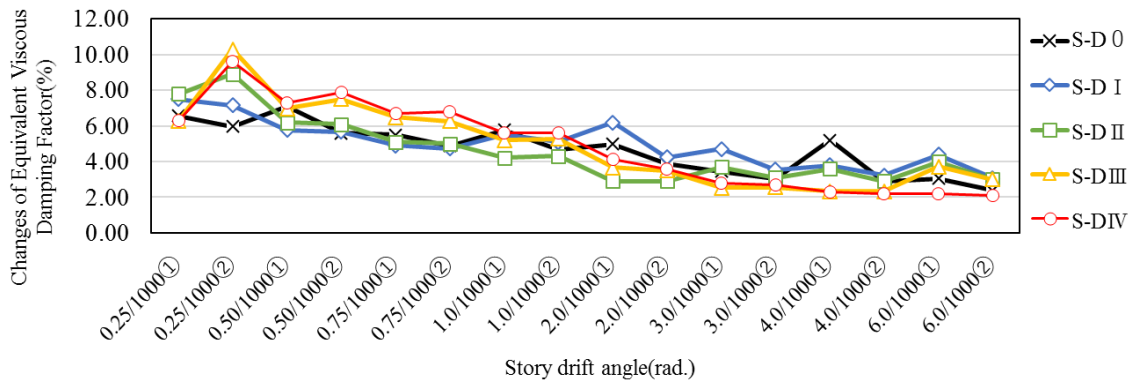

Fig.14– Equivalent viscous damping factor

5. Consideration by FEM Analysis

5.1 Analysis condition

The simulation by FEM analysis was performed and applicability of analysis was verified. The nonlinear FEM analysis program of RC structure CARC-ASe[9] was used in the analysis with the two-dimensional model. Fig.15 shows an analytical model used for analysis. This analysis program adopts the non-orthogonal 4-way directions cracking model developed by Maekawa and Fukuura[10].

In the analytical model, concrete was represented by four-node plane elements, wall reinforcements and column hoop reinforcements were by laminated rebar elements, and column longitudinal reinforcements were represented by rod elements. Column longitudinal reinforcements were connected to concrete with bond element. Material properties of concrete and reinforcements used for the analysis were given from material test results.

5.2 Analysis results

Fig.16 shows the comparison of experiments and analysis of the shear force-story drift angle relationships and the points where the wall reinforcements start yielding for the non-damaged specimen S-D0 and damaged specimens S-DI · III · IV. And, Table 6 shows the comparison of maximum strength of each cases. The shear force-story drift angle relationships show only main loading, and the range of deformation by pre-loading is indicated in Fig.16.

Analysis result of non-damaged specimen S-D0 corresponded to experiments well both in maximum strength and cyclic characteristics. Analysis is also consistent with the experiment for the point where the wall reinforcements start yielding.

For the damaged specimens S-DI and S-DIII, the analysis simulates well both the deformation level where damage occurred from preloading and the deformation level without damage, and the maximum strength is also evaluated well. On the other hand, the stiffness of analysis during pre-loading range in SD-IV, that has experienced large deformation such as 6/1000rad, was higher than that of experiment. However, maximum strength that occurred in no-damage deformation level was evaluated well in the analysis.

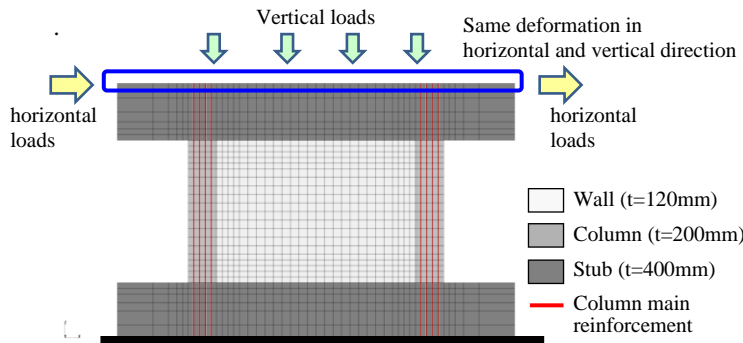

Fig.15 – Analytical model

Table 6 Maximum strength

Specimen	Experiment (kN)	Analysis (kN)	Analysis/Experiment
S-D0	2014	2009	1.00
S-DI	2147	2037	0.95
S-DIII	1969	2042	1.04
S-DIV	2058	2057	1.00

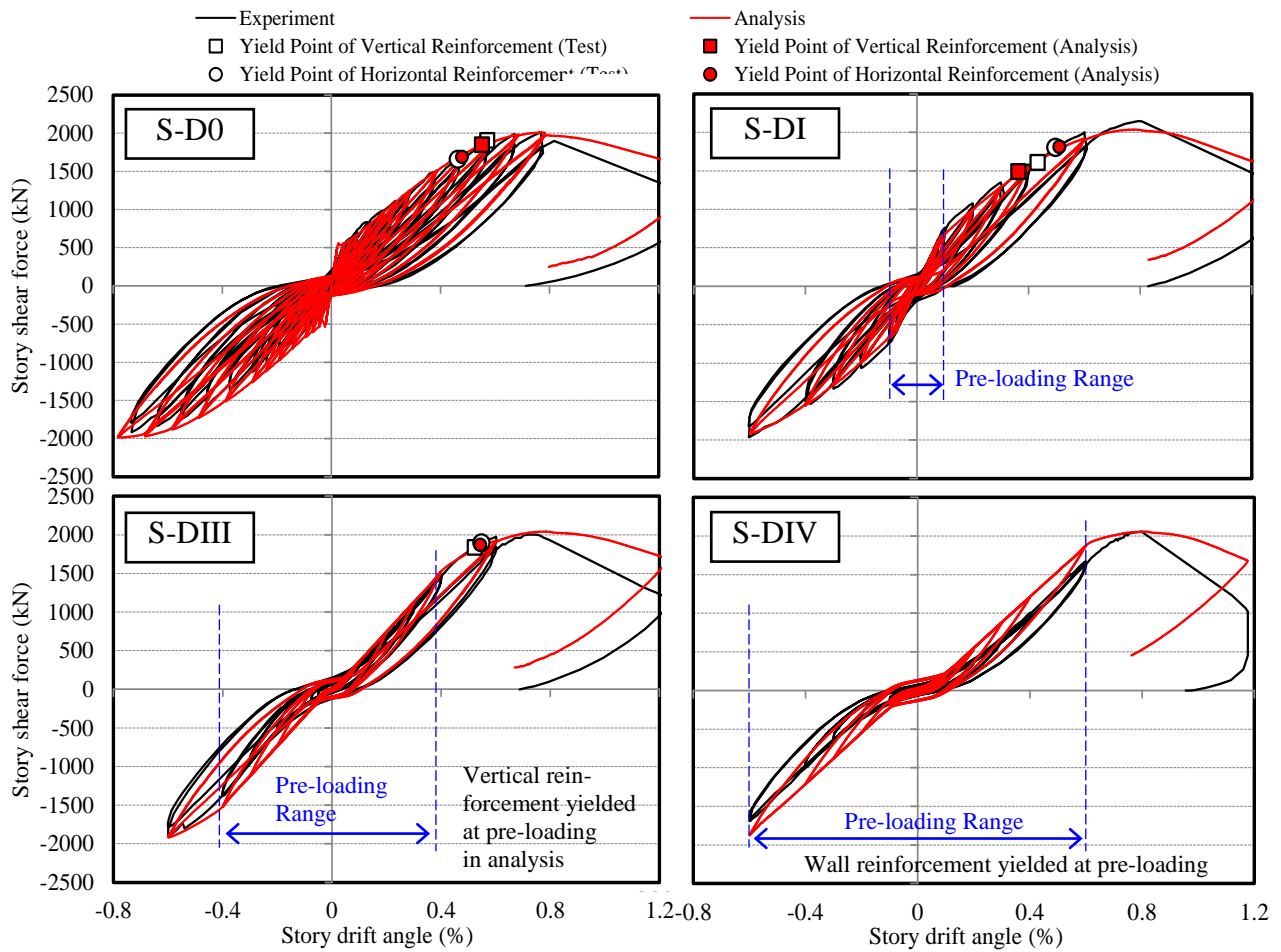

Fig.16 – Comparison of analysis and tests



6. Conclusion

Experimental studies of RC shear wall were carried out to investigate the relationship between damage levels and structural performance. It was found that the damage induced shear walls does not significantly affect ultimate performances such as maximum strength, deformation capacity and damping capacity. From this results, stiffness degradation due to damage (cracking) induced by previous loading does not correspond to deterioration of seismic performance of shear walls investigated in this paper.

FEM analysis evaluated well the performance such as shear strength and ultimate deformation for not only undamaged but also damaged specimens except stiffness during pre-loading range in heavily damaged specimens that has experienced large deformation such as 6/1000rad.

7. Acknowledgements

This experiment was conducted as cooperative reserch between Tohoku Electric Power Co. And Tohoku University. I would like to express my gratitude to whom it may concern.

8. References

- [1] Japan Building Disaster Prevention Association(JBDPA) (2001): Standard for Post-Earthquake Damage Level Classification of Reinforced Concrete Building.
- [2] Nakano Y, Maeda M, Kuramoto H, Murakami M, Guideline for Post-Earthquake Damage Evaluation and Rehabilitation of RC Buildings in Japan, *Proceedings of the 13th World Conference on Earthquake Engineering 2004*; paper No.124
- [3] Maeda M, Nakano Y, Lee KS. Post-Earthquake Damage Evaluation for R/C Buildings based on Residual Seismic Capacity. *Proceedings of the 13th World Conference on Earthquake Engineering 2004*; paper No.1179
- [4] MAEDA M, Kang DE. (2009) "Post-Earthquake Damage Evaluation of Reinforced Concrete Buildings", *Journal of Advanced Concrete Technology*, **7** (3): 327-335.
- [5] Kiyoshi Hirotsu et al. (2012): Simulation Analysis of Earthquake Response of Onagawa Nuclear Power Plant to the 2011 off the Pacific Coast of Tohoku Earthquake, 15WCEE
- [6] Architectural Institute of Japan (AIJ). (1999): Design Guidelines for Earthquake Resistant Reinforced Concrete Building Based Inelastic Displacement Concept
- [7] Architectural Institute of Japan (AIJ). (2010): AIJ Standard for Structural Calculation of Reinforced Concrete Structures
- [8] Nuclear Standards Committee: Technical Code for Seismic Design of Nuclear Power Plants, JEAC4601-2008
- [9] Morikawa H. et al. (2006): "Nonlinear Finite Element Analysis of Reinforced Concrete Structures under Cyclic Loading", *Kajima Technical Research Institute Annual Report*, Vol.54, 57-62.
- [10] Fukuura N, Maekawa K. (1999) Spatially averaged Constitutive law for RC in-plane elements with non-orthogonal cracking as far as 4-way directions, *Journal of JSCE, JSCE*, No.634, 177-195